

cinema projector series
cineo30

true 1080p resolution
full BrilliantColor™
up to 6500 ansi lumens
failsafe DuArch™ operation



The cineo30 is designed for markets where more brightness, more power, and a higher image quality is needed. With full 1080p HD and a wide range of configuration options, it is prime time.

True HD digital eCinema projector

The new projectiondesign cineo30 1080 is the first true HD single chip 1080p DLP® projector to utilise Texas Instruments® new BrilliantColor™ technology to its full extent. With better colours, a higher dynamic range, and better image quality than any single chip DLP® projector before it, it has been designed to fit into demanding applications such as post production and grading suites, or larger auditoriums and smaller cinemas.

BrilliantColor™ technology

By fully utilising BrilliantColor™, the cineo30 1080 has a wider gamut, with better colour saturation, and truer colours than ever before. New colour wheel technology allows adding not only RGB, but also Cyan, Magenta, and Yellow to the picture, which means less colour contamination, and extra saturation to the natural colours that are incredibly difficult to display with only red, green, and blue primary colours. In addition, BrilliantColor™ adds midrange punch and brightness, allowing for a much more dynamic video experience, and with better suitability for larger scenes.

Designed for reliability

The cineo30 1080 shares numerous features with its professional product siblings to provide failsafe operation. At the heart of the projector sits the patented DuArch™ illumination architecture that allows for Hot Swapping of lamps while still in operation, and keeping the image on screen. DuArch™ features dual colour wheels, dual illumination optimisers, and dual illumination optics. For monitoring, a backlit LCD status panel is available for immediate and configurable status overview and events logging. In addition, direct view status lights are available, so there is no doubt whether all systems are OK. The cineo30 also features complete control and asset management over TCP/IP from any remote computer, using standard tools, or through our own ProNet asset management software.

Configuration options

The cineo30 1080 can be set up with any one of six different projection lenses, covering a wide range of projection ratios, from ultra wide to ultra long throw, ensuring it fits in any installation. Matching that with the range of available colour wheels, and most requirements should be taken care of.



High performance optics

The key to optimum image quality, and installation flexibility is ensured with a wide range of projection lenses, covering every need from 0.79 – 6.5 : 1. All lenses are user replaceable and can be shifted $\pm 125\%$ vertically and $\pm 90\%$ horizontally, giving a total freedom in placement of the projector.

RealColor and BrilliantColor™

Our proprietary RealColor technology simplifies set up routines and calibration, and ensures a near perfectly rendered image with any given input source. By combining it with Texas Instruments® BrilliantColor™ technology, a wide gamut, strongly saturated image is projected.

High Brightness

The cineo30 1080 outputs enough brightness to easily fill an 11m / 35 ft wide screen to the SMPTE specifications, at 14ftL off-screen reflected light. For smaller screens, the brightness can be reduced to still fill the exact same requirement, with prolonged lamp life.

Full 10-bit colour resolution and HDMI 1.3

The cineo30 1080 provides true 10-bit resolution per colour, for a total of >1 Billion simultaneously displayable colours. Reduced image gradation and solarization effects, and the high bandwidth (225 MHz) of HDMI 1.3 with support for 12-bit Deep Color seures a future proof investment. Our unique DPEq (Digital Pixel Equalization) allows up to 30m long HDMI and DVI runs without loss of signal and image quality, when using 24 AWG cables.

projectiondesign ProNet asset management

Optional asset management software allows easy management in large site installations, or even multi-site installations, supporting hundreds of projectors from a single interface.

Wide range of projection lenses

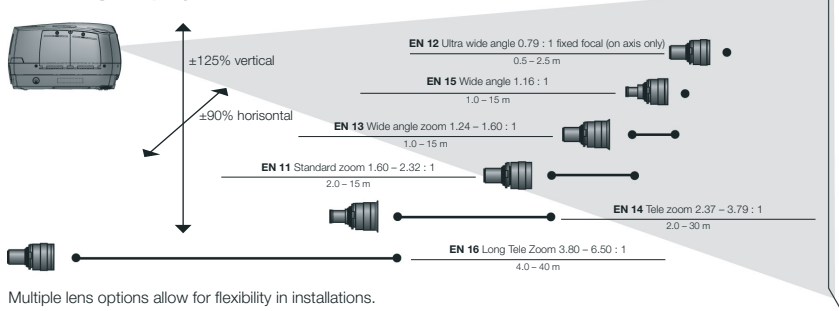

Available versions

Colour Wheel	1920 x 1080
VizSim (RGBCMY) (standard)	101-1410-xx
Graphics (RGBCYW) (option)	101-1409-xx
High Brightness (RGBCYW) option	101-1411-xx
DCI compliant colour space (RGBRBGB) option	101-1420-xx
Available colours: black metallic -08 (standard), silver -14 (option)	

technical specifications

projector		cineo30 1080
display	technology	1080p HDTV DLP® digital projector
	resolution	0.95" 1080p DC3™ DMD™ (Digital Micromirror Device)
	brightness	1920 x 1080 pixels (full 1080p HDTV) up to 6500 ANSI lumens (typ) >14ftL at 11.5m wide screen at 1.8 gain up to 7500 : 1 (user configurable)
optics and lamp	contrast ratio	16 : 9, 1.85, 2.35 and 1.33:1 compatible
	aspect ratio	30-bit (> 1 Billion displayable colours)
	colours	six options covering 0.79 - 6.5 : 1 0.5 - 40m / 1.5 - 130 ft (customizable) Vertical: $\pm 125\%$ Horizontal: $\pm 90\%$
lamps	available lenses	2x300W UHP™
	focusing distance	2000 hours full power mode, 2500 hours at 80% 4000 / 5000 hours in single lamp relay mode
	optical lens shift	
connectivity	digital	1x HDMI 1.3 (HDCP) with DPEq 1x DVI-I (HDCP) with DPEq
	analogue	3x RGBHV (5x BNC, 15-pin HDSUBS and DVI-I) 1x component video, 1x S-video, 1x video
compatibility	optional input module	HD-SDI, SDI
	digital	1x HDMI / 1x DVI-D (480p to 1080p at 24/25 fps, 48, 50, 59.94 60 Hz – up to 225 MHz pixelrate) 1x HD-SDI / SDI (optional I/O panel)
general	analogue	RGBHV, RGBS, RGSB, virtually any signal up to 1920 x 1200 at 60 Hz and 205 MHz pixelrate
	asset management	projectiondesign ProNet – asset management software for an unlimited number of projectors
control	control	RS-232C (in/out), TCP/IP, IR, 2x 12V triggers
	operating noise level (typ)	30 dB (A) at 20°C/ 68°F, sea level
	dimensions (dwh)	376 x 510 x 223 mm (excluding lens)
	weight	12.6 kg / (excluding lens)
	supplied accessories	IR remote control, cable kit
	power requirements	90 – 240 VAC, 50/60 Hz, +/- 10%, <1050W
	conformances	CE, CSA "C/US", FCC Class A, CCC
	available colour	black metallic, silver metallic
	warranties	2 years parts and labour, 500 hours or 90 days on lamp, conditions apply 3rd year warranty optional

Standardised bolt-on ceiling mount interface

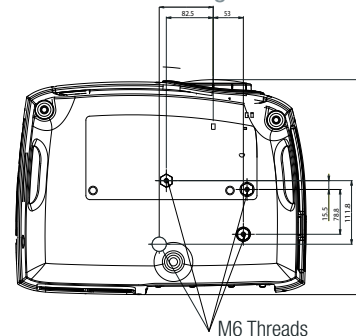

Expandable input panel



The comprehensive input panel features HDMI 1.3 and DVI-D for high resolution digital imaging, and can be expanded with HD-SDI and SDI input modules.

Distributed by:

