

QuickMedia® Wall Plate Media Center

Crestron® MediaManager is a comprehensive family of affordable products fusing high-performance AV signal distribution, device control, and facility-wide system management. MediaManager simplifies the art of ProAV system design and installation with complete hardware, software, and low-cost wiring solutions. Whether installing a single boardroom or a campus-wide network of AV systems, MediaManager delivers power and value far beyond conventional products and designs.

The QM-WMC QuickMedia® Wall Plate Media Center provides an elegant wall mount multimedia interface solution for any MediaManager system, including applications ranging from small conference rooms to large banquet halls and auditoriums.

Wall Mount Multimedia Interface

The QM-WMC installs cleanly in a standard electrical box or trim ring. Individual inputs are provided for composite, S-Video, and RGB/component signals, each with corresponding stereo audio, to accept connections from portable AV devices and computers. A buffered monitor pass-thru connector is also provided to feed the RGB input signal to a local monitor.

Connectivity for LAN and other signals can easily be added by ganging the QM-WMC together with other 3rd-party wall plate devices. A Crestron **C2N-DB** or **C2N-CBD** series keypad may also be installed for a truly complete multimedia interface and control solution. Wiring for the QM-WMC is extremely simple requiring just a single **CresCAT®QM** cable (sold separately).

AV Switcher

The built-in 3X1 switcher includes audio breakaway to allow the three program audio inputs to be switched independent of the video and RGB inputs, or linked with them. Built-in video sensing on every video/RGB input can be utilized to trigger automatic input selection and power control.

Gated Mic Preamp (Optional)

Two gated microphone inputs may be added using the **QM-WMIC** Microphone Input Module (sold separately). Via two Neutrik® Combo connectors, the QM-WMIC supports both dynamic and condenser type microphones with software switchable 48V phantom power available at both XLR inputs. Balanced or unbalanced line-level sources can also be accommodated using the 1/4" TRS connections. Input gain and gating controls for each microphone/line input are fully adjustable at setup, and can also be controlled in real-time from a keypad or touchpanel.

QuickMedia® Transport

Using the revolutionary QuickMedia transport, all input signals are transmitted from the QM-WMC to any QuickMedia Receiver or Distribution Center over a single inexpensive CAT5e type cable^[1]. Computer resolutions up to 1920 X 1200 pixels at 60Hz are supported over cable runs up to 450 feet. Audio signals are transmitted digitally with high-performance 24-bit resolution. QuickMedia dramatically simplifies system design and installation, affording a higher level of performance at a lower overall cost.

MediaManager System Integration



Whether using just one Wall Plate Media Center or several, complete system operation can be made transparent to the end-user with all signal routing occurring smoothly under the command of the MediaManager control system. Complete MediaManager systems are easy to design, program and adjust from start to finish using Crestron **SystemBuilder?** software.

- > *Stylish wall plate multimedia interface*
- > *Composite, S-Video and RGB/component inputs*
- > *Buffered RGB monitor pass-thru*
- > *3 stereo audio inputs plus optional 2 gated mic/line inputs*

- > *3X1 switcher with audio breakaway*
- > *Video sensing | auto-switching*
- > *QuickMedia transport | Cresnet communications*
- > *Low-cost, quick and easy installation*
- > *Integrates with Crestron Cameo and Decorator keypads*
- > *Installs alongside 3rd-Party LAN jacks and other devices*
- > *Easy setup using Crestron SystemBuilder software*

SPECIFICATIONS

Video

Signal Types: RGB and composite, S-Video, or component^[2] video

Video/HDTV Formats: NTSC or PAL, HDTV up to 1080i/1080p^[2]

RGB Formats: RGBHV, RGBS, or RGsB

Gain: 0dB (75 ohms terminated)

Maximum Resolution: 1920 x 1200 @ 60Hz (at unity gain) with maximum cable length of 450 feet and maximum compensation at receiver

Audio

A-D Conversion: 24-bit, 48 kHz

Frequency Response: 20Hz to 20kHz

QM-WMCQuickMedia® Wall Plate Media Center

Communications

QuickMedia: QM origination point device^[1]

Cresnet: Cresnet slave device

Connectors - Front Panel

S-VIDEO: (1) 4-pin mini DIN female, S-Video (Y/C) input;

Input Impedance: 75 Ohms;

Maximum Input: 1 Vp-p;

Signal sensing on Y

S-VIDEO AUDIO R, L: (2) RCA female;

Unbalanced stereo line-level audio input;

Input Impedance: 10k Ohms;

Maximum Input Level: 2 Vrms

VIDEO: (1) RCA female, composite video input;

Input Impedance: 75 Ohms;

Maximum Input: 1 Vp-p;

Includes signal sensing

VIDEO AUDIO R, L: (2) RCA female;

Unbalanced stereo line-level audio input;

Input Impedance: 10k Ohms;

Maximum Input Level: 2 Vrms

COMPUTER: (1) DB15HD female;

RGB(VGA)/component video input^[2];

Formats: RGBHV, RGBS, RGsB, YPbPr;

Input Impedance: 75 Ohms;

H Sync Impedance: 1k Ohms;

V Sync Impedance: 2.2k Ohms;

Maximum Input Level: 1 Vp-p;

Maximum Sync Level: 5 Vp-p;

Signal sensing on H-SYNC only

AUDIO (computer): (1) 3.5mm TRS mini phone jack;

Unbalanced stereo line-level audio input;

Input Impedance: 10k Ohms;

Maximum Input Level: 1 Vrms

MONITOR: (1) DB15HD female, buffered RGBHV pass-thru

Connectors - Rear Panel

QM: (1) 8-wire RJ45 female, QuickMedia output port;

Connects to QM input port of any QuickMedia device via **CresCAT-QM** or **CresCAT-IM** cable^[1]

NET: (2) 4-pin 3.5mm detachable terminal blocks;

Cresnet slave ports, paralleled; connect to Cresnet control network via

CresCAT-QM or **Cresnet** cable

GROUND: (1) Flying lead, grounding wire

TO MIC: (1) 14-pin header;

Accepts connection from optional **QM-WMIC** (sold separately)

Controls & Indicators

PWR: (1) green LED, indicates 24 Volts DC power supplied from Cresnet network

NET: (1) yellow LED, indicates communication with Cresnet system

SETUP: (1) miniature pushbutton and red LED, used for touch-settable ID (TSID)

COMP: (1) red LED, indicates a signal at the COMPUTER input

VIDEO: (1) red LED, indicates a signal at the VIDEO input

S-VID: (1) red LED, indicates signal at the S-VIDEO input

Dimensions

Height: 4.12 in (105 mm)

Width: 3.50 in (89 mm)

Depth: 2.61 in (67 mm)

Weight

8.0 oz (230 g)

Available Models

QM-WMC [6500114]: QuickMedia Wall Plate Media Center [Limited Supply]

Available Accessories

CRESCAT-QM-NP-SP500 [6500606]: QuickMedia® Cable, Low-skew CAT5e & Cresnet, non-plenum, 500 ft spool [Limited Supply]

CRESCAT-QM-P-SP500 [6500439]: QuickMedia® Cable, Low-skew CAT5e & Cresnet, plenum, 500 ft spool [Limited Supply]

QM-WMIC [6500115]: Microphone Input Module [Limited Supply]

Notes:

1. For QuickMedia wiring use **CresCAT-QM**, **CresCAT-IM**, or quality CAT5e/CAT6 cable with a delay skew of =15ns per 100m; the maximum aggregate cable length and delay skew between any QM transmitter (origination point) and QM receiver (endpoint) is 450 ft (137 m) and 22 ns; a maximum of two QM midpoint devices may be inserted in a given QM signal path; exceptions apply, refer to each respective product manual for full detail.

QM-WMC QuickMedia® Wall Plate Media Center

QM Multipoint Solution

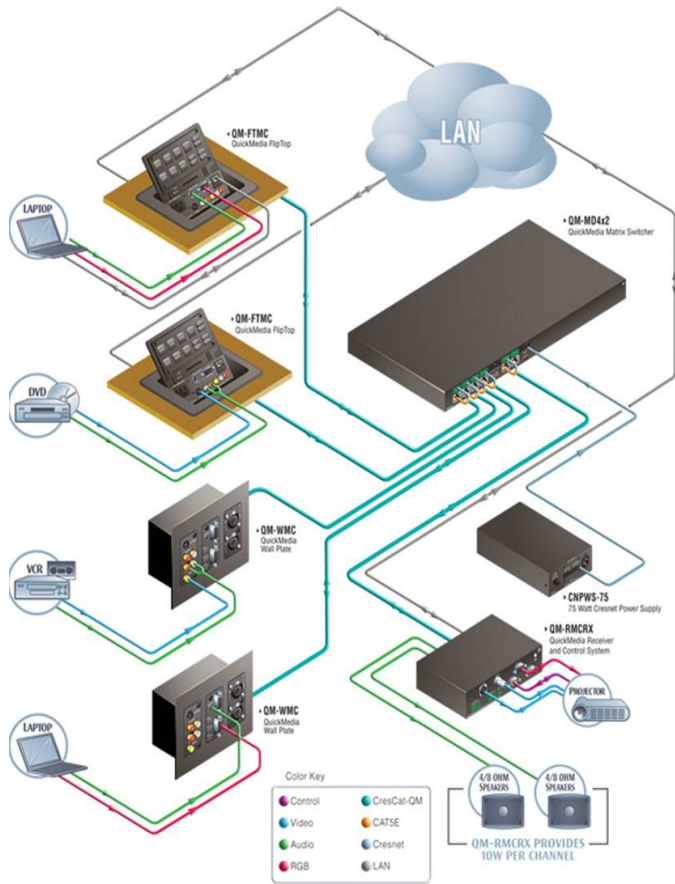

QuickMedia AV Rack Solution with Portable Media

QuickMedia Example - Using Portable Media

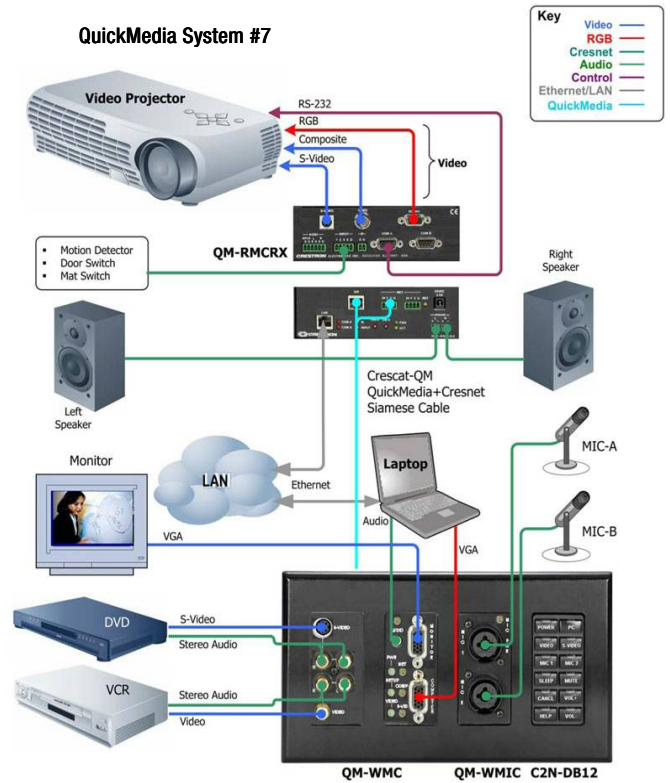

QM-WMC QuickMedia® Wall Plate Media Center

Typical QM-WMC Application

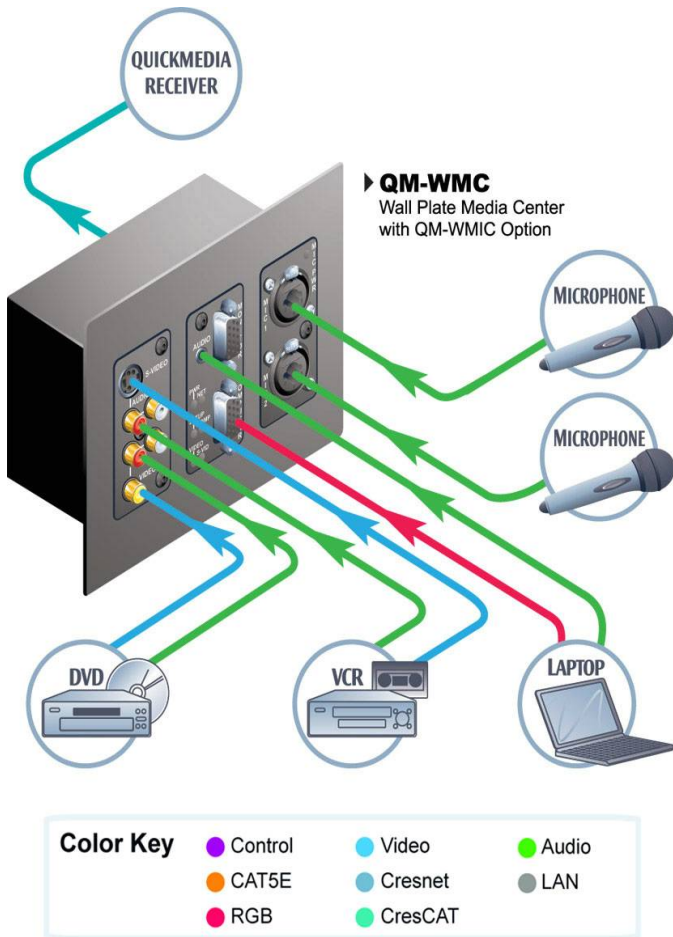

QM-WMCQuickMedia® Wall Plate Media Center

